

TABLE OF CONTENTS – INDUSTRIAL ACCESSORIES

FRP Balancing Series Damper [BA]: Specification, Model Number Designation and Drawing	1
--	----------

FRP Zero Leak Damper [ZL]: Specification, Model Number Designation and Drawing	4
---	----------

FRP Volume Damper Drawing Specification Sheet	7
--	----------

FRP Blast Gate Drawing Specification Sheet	8
---	----------

Grease Filter Specification	9
------------------------------------	----------

Mist Eliminator Specification	11
--------------------------------------	-----------

Fibersonic Silencer[™] Construction Specification	13
---	-----------

BA SERIES FRP DAMPER SPECIFICATION

Dampers:

- A. BA Series FRP Dampers shall be manufactured by Spunstrand® Inc. and fabricated with the same materials and specifications as the duct. BA dampers are to be used in areas for balancing where ultra low leakage is not critical. Leakage rates are designed to be approximately 5%. Resin shall be Ashland Chemicals Hetron 992SB or Derakane 510 vinylester resin; 100 mil liners to be clear without antimony trioxide and fabricated to meet ASME RTP-1 visual level II acceptance quality. Structural layers to be filament wound with the same resin and include antimony trioxide for maximum fire retardency. Unless otherwise specified, minimum wall thickness shall be .150" for 4"Ø thru 22"Ø, .200" for 24"Ø thru 36"Ø, .250" for 42"Ø thru 54"Ø, .325" for 60"Ø thru 72"Ø. No resin, liner or structural variations will be acceptable unless they exceed the minimum requirements. Blade shall be FRP one or two piece molded, depending on diameter, and include blade stiffeners as needed for proper blade stiffness. Damper blade shall be offset in the closed position to form a normal stop on wall of duct. The seating of the blade shall be independent of the shaft seal. Axle to be pultruded FRP made with same resin as the duct and continuous strand roving. Standard bearing to be Teflon with double O-rings. Shaft seals are also included as standard with no metal parts or cut edges in air stream allowed. The BA design and O-rings eliminate the need for outboard bearings and packing glands, which become maintenance items over time. Dampers, including all components other than mechanical operators, to be manufactured by Spunstrand® Inc.
- B. All dampers shall be factory tested for full range of motion, blade fit, quality of each individual component and results shall be documented and included in the Fabricators Quality Control Manual QC Forms and Procedures.
- C. Dampers come standard with flanges that require mating flanges on the connecting duct work but can also be supplied with plain ends or in spool pieces. It is important to note that when supplied with plain ends, the installer needs to take great care to keep excess resin away from the dampers moving parts while they are making joint connections. Dampers come as standard manual configuration with FRP locking quadrant handles or with gear operators as an option.
- D. All Spunstrand® Inc. damper shafts are fabricated by pultruding vinylester resin and continuous strand roving. Stainless steel shafts are available as an option, but are not recommended in applications with high concentrations of acids or caustics.
- E. Motorized dampers are available with either pneumatic or electric actuators. Standard torque ratings available in 100 and up to 3600 in / lb ratings. Positioners and other options and controls are available upon request.

**SPUNSTRAND® INC. BA SERIES FRP DAMPERS
MODEL NUMBER DESIGNATIONS**

DIAMETER	BODY CONSTRUCTION*	BLADE CONSTRUCTION*	O-RING MATERIAL
4" THRU 96"	P - Polyester	1 - Polyester	1 - Neoprene
			2 - Buna N
			3 - EPDM
	V - Vinylester	2 - Vinylester	4 - Viton
			5 - Butyl
			6 - Fluorocarbon
<u>60"</u>	<u>V</u>	<u>2</u>	<u>3</u>

<u>F</u>	<u>B</u>	<u>B</u>	<u>MO</u>
BODY CONFIGURATION	SHAFT MATERIAL ⁽²⁾	LINER THICKNESS	OPERATORS ⁽²⁾
F- Flanged	A - Polyester	A - 20 mil	M - FRP Locking Quad
P - Plain Ends		B - 100 mil	MP - Position Throttling Handle
D - Located per Drawing	B - Vinylester	C - Per Cust. Spec.	G - Gear Operators
			C - Chain Operator
			MO - Motorized Operator

Example above part number is:

BA 60 F V B 2 B 3 MO

This part number designates a 60"Ø Balancing Damper with a flanged vinylester body, a vinylester shaft and blade, 100 mil RTP-1 liner, EPDM O-Rings, and a motorized operator.

* Both polyester and vinylester are premium grade and fire retardant resins as standards.

1. Motorized operators are either electric or pneumatic. Standard torque ratings for all BA style dampers are available upon request. Positioners and other options as requested.
2. All BA Series dampers come with FRP bearings and o-rings shaft seals provided as standard. Teflon packing glands are available as an option.

BA DAMPER DRAWING SPECIFICATION SHEET

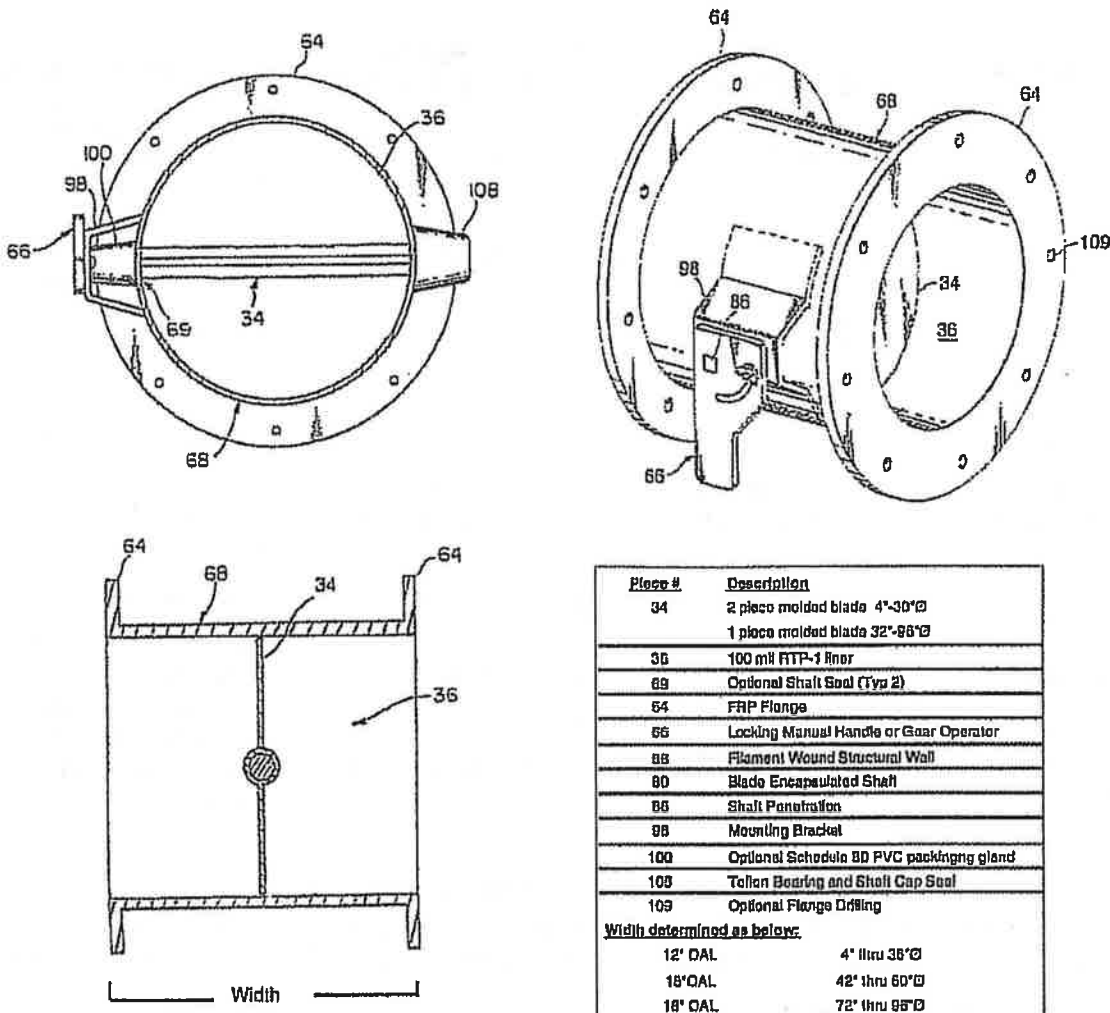

Part #	Description
34	2 piece molded blade 4"-30"Ø 1 piece molded blade 32"-88"Ø
36	100 mil FRP-1 liner
68	Optional Shaft Seal (Type 2)
64	FRP Flange
66	Locking Manual Handle or Gear Operator
88	Filament Wound Structural Wall
80	Blade Encapsulated Shaft
86	Shaft Penetration
98	Mounting Bracket
100	Optional Schedule 80 PVC packing gland
108	Teflon Bearing and Shaft Cap Seal
109	Optional Flange Drilling
<u>Width determined as below:</u>	
12" OAL	4" thru 36"Ø
18" OAL	42" thru 60"Ø
18" OAL	72" thru 88"Ø

RESIN TYPE: [] POLYESTER [] VINYLESTER [] FACTORY MUTUAL **OPTIONAL :** [] MOTORIZED

CONSTRUCTION	BLADE THICKNESS	AXLE DIM.	BLADE STIFFENERS	SCALE NTS	APPROVED BY JMS	DRAWN BY W.K.G.
4" thru 10"	.125	1.0"	0	DATE 8/10/94	REVISED 3/15/89	
12" thru 20"	.125	1.0"	1	SPUNSTRAND INCORPORATED FRP BALANCING DAMPER		
22" thru 36"	.187	1.5"	1-2	DRAWING NO.: DRP 102BA		
42" thru 66"	.250	2.0"	3			
72" thru 96"	.312	2.5"	3			

ZL (ZERO LEAK) SERIES FRP DAMPER SPECIFICATION

Dampers:

- A. ZL Series FRP Dampers shall be manufactured by Spunstrand® Inc. and fabricated with the same materials and specifications as the duct. Resin shall be Ashland Chemicals Hetron 992SB or Derakane 510 vinylester resin: 100 mil liners to be clear without antimony trioxide and fabricated to meet ASME RTP-1 visual level II acceptance quality. Structural layers to be filament wound with the same resin and include antimony trioxide for maximum fire retardancy. Unless otherwise specified, minimum wall thickness shall be .150" for 8" Ø thru 22"Ø, .200" for 24"Ø thru 36"Ø, .250" for 42"Ø thru 54"Ø, .375" for 60"Ø thru 72"Ø, .415 76"Ø thru 84"Ø, and .500 for 96"Ø. No resin, liner, or structural variations will be acceptable unless they exceed the minimum requirements. Blade shall be FRP one or two piece molded, depending on diameter, and include blade stiffeners as needed for proper blade stiffness. Damper blade shall be offset in the closed position to form a normal stop on wall of duct. The seating of the blade shall be independent of the shaft seal. A resilient rubber seat shall be permanently formed into the duct wall. The resilient seat to be butyl vinyl as standard with other optional seats available. Axle to be pultruded FRP made with same resin as the duct and continuous strand roving. Bearing to be Teflon® with machined in o-rings. External schedule 80 PVC packing glands with Teflon® packing are included as standard. Dampers, including all components other than mechanical operators to be manufactured by Spunstrand® Inc.
- B. All dampers shall be factory tested for full range of motion, blade fit, quality of each individual component, leakage tested with results documented and included in the fabricator's Quality Control Manual QC forms and procedures.
- C. Dampers come standard with flanges that require mating flanges on the connecting ductwork but can also be supplied with plain ends or in spool pieces. It is important to note that when supplied with plain ends the installer needs to take great care to keep excess resin away from the damper's moving parts while they are making joint connections. Dampers come as standard configuration with gear operators required for the additional torque created by the resilient seat.
- D. All Spunstrand® Inc. damper shafts are fabricated by pultruding vinylester resin and continuous strand roving. Stainless steel shafts are available as an option, but are not recommended in applications with high concentrations of acids or caustics.
- E. Motorized dampers are available with either pneumatic or electric actuators. Standard torque ratings available in 100, and up to 5,000 in/lb ratings. Positioners or other options and controls available upon request.

**SPUNSTRAND® INC. ZL SERIES FRP DAMPERS
MODEL NUMBER DESIGNATIONS**

DIAMETER	BODY CONSTRUCTION*	BLADE CONSTRUCTION	O-RING MATERIAL
4" thru 96"	P - Polyester	1 - Polyester	1 - Neoprene
	V - Vinylester	2 - Vinylester	2 - Buna N
	E - Epoxy		3 - EPDM
	S - Same as Duct Spec ⁽¹⁾	3 - Epoxy	4 - Viton
76"	V	2	5 - Teflon® 6 - Fluorocarbon

F	B	BV	CS
BODY CONFIGURATION	SHAFT MATERIAL ⁽³⁾	SEAT MATERIAL	OPERATORS ⁽¹⁾
F - Flanged	A - Polyester	N - Neoprene	G - Gear Operator
		V - Viton	
P - Plain Ends	B - Vinylester	E - EPDM	C - Chain Operator
	C - Epoxy	BV - Butyl Vinyl	MD - Motorized Operator
D - Located per Drawing	D - 316SS	S - Silicone	CS - Customer Supplied
		B - Buna N	

Example above part number is:

ZL 76 F V B 2 BV 4 G

This part number designates a 76" Ø Zero Leak damper with a flanged vinylester body, a vinylester shaft and blade, Butyl Vinyl seat, Viton "O" Rings and a gear operator.

* Both polyester and vinylester are premium grade and fire retardant resins as standards.

- Standard Liner construction is 100 mil minimum with ASME RTP-1 visual level II acceptance criteria, unless specified otherwise. ZL bearings are Teflon® with machined o-ring grooves. External schedule 80 PVC packing glands with Teflon® packing are also standard.
- Motorized operators are available with either pneumatic or electric actuators. Standard motor torque ratings available in 100 up to 5,000 in / lb ratings. Positioners and other options or controls are available on request.

ZL DAMPER DRAWING SPECIFICATION SHEET

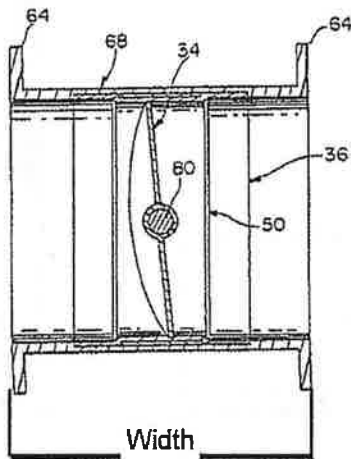
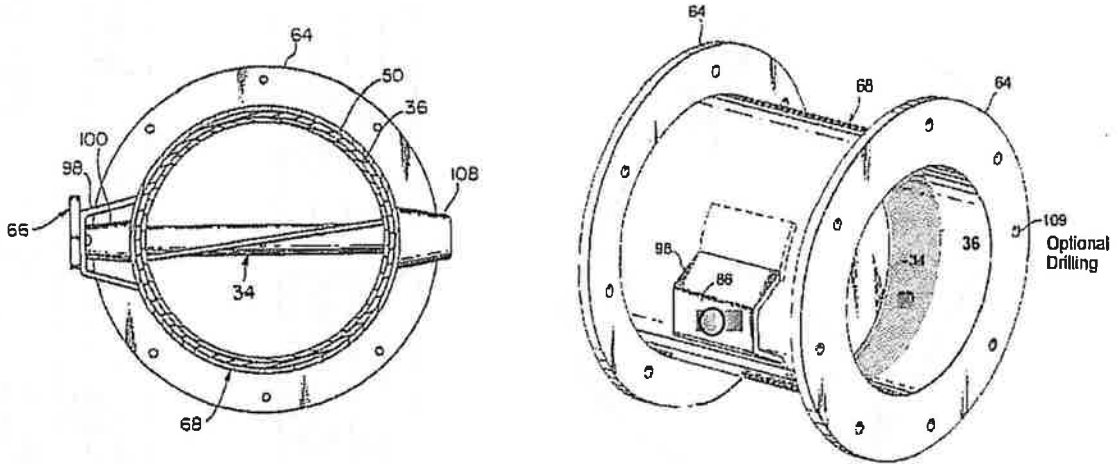

PIECE #	DESCRIPTION
34	2 piece molded blade 4"Ø-30"Ø 1 piece molded blade 32"Ø - 96"Ø
36	100 mil RTP-1 liner
50	Resilient Seal Butyl Vinyl standard
64	FRP Flange
66	Gear or Motorized Operator
68	Filament wound structural wall
60	Blade encapsulated shaft
65	Shaft penetration
98	Mounting bracket
100	Schedule 80 PVC packing gland
108	Teflon™ bearing and shaft cap seal
Width determined as below:	
12" OAL	8" thru 24"Ø
15" OAL	25" thru 42"Ø
18" OAL	48" thru 60"Ø
24" OAL	72" thru 96"Ø

RESIN TYPE: [] VINYLESTER [] FACTORY MUTUAL **OPTIONAL SEAT:** [] VITON [] EPDM

CONSTRUCTION	BLADE THICKNESS	AXLE DIM.	BLADE STIFFENERS	SCALE NTS	APPROVED BY J.M.S.	DRAWN BY W.K.G.
4" thru 14"	.125	1.0"	0-1	DATE	REVISED	
16" thru 24"	.187	1.5"	2	SPUNSTRAND INCORPORATED FRP ZERO LEAK DAMPER		
30" thru 48"	.312	2.0"	3	DRAWING NO.: DRP 103ZL		
54" thru 60"	.312	2.5"	3			
72" thru 80"	.350	3.0"	3			
84" thru 96"	.375	3.0"	4			

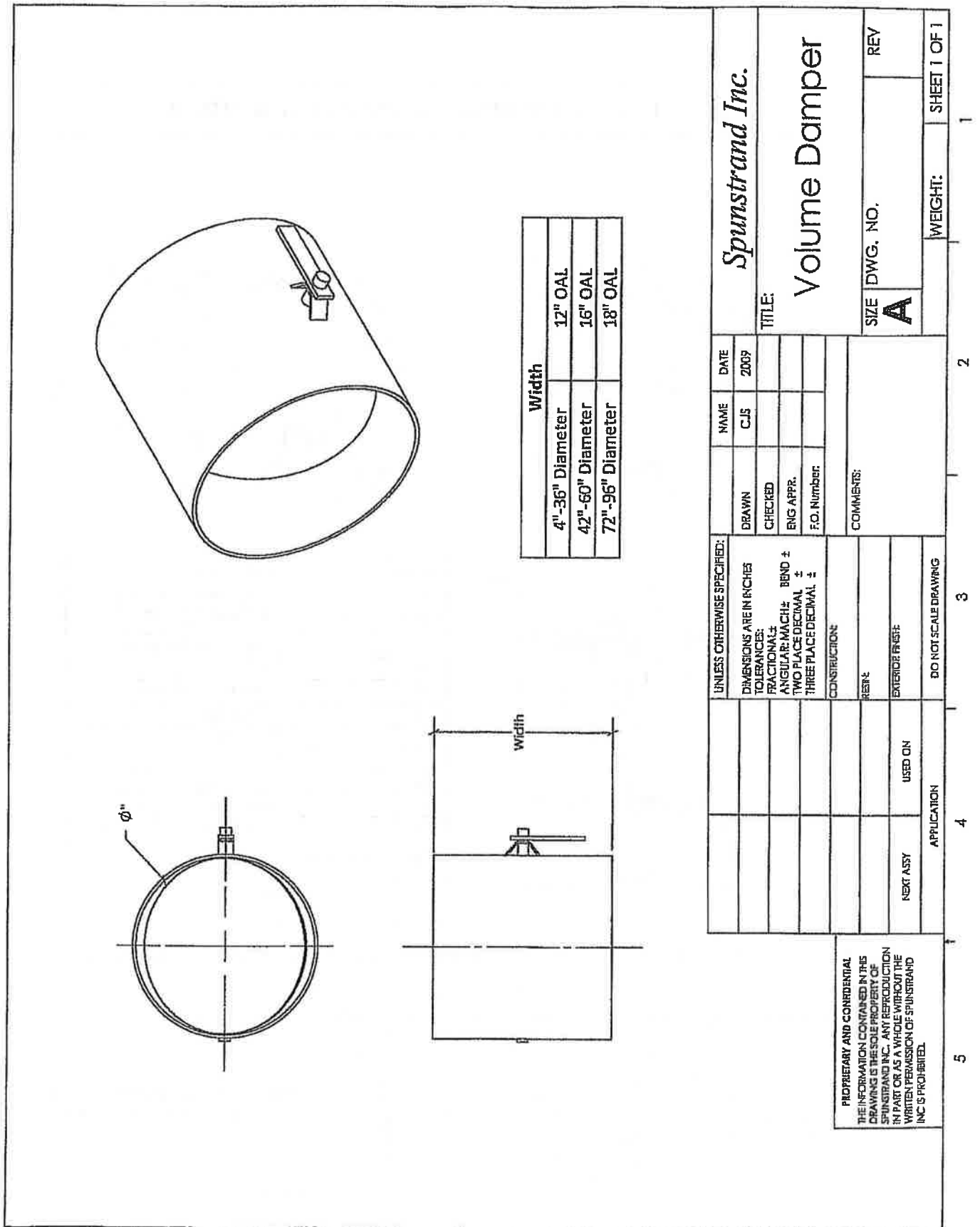

<p>Spunstrand Inc.</p>		DATE	2009
		NAME	CJS
<p>TITLE:</p> <p>Volume Damper</p>		DRAWN	CJS
<p>SIZE DWG. NO.</p> <p>A</p>		CHECKED	
<p>REV</p>		ENG APPR.	
<p>WEIGHT:</p>		F.O. Number:	
<p>SHEET 1 OF 1</p>		COMMENTS:	
<p>UNLESS OTHERWISE SPECIFIED:</p> <p>DIMENSIONS ARE IN INCHES</p> <p>TOLERANCES:</p> <p>FRACTIONAL: ±</p> <p>ANGULAR: MACH ± BEND ±</p> <p>TWO PLACE DECIMAL ±</p> <p>THREE PLACE DECIMAL ±</p>		CONSTRUCTION:	
<p>REIN:</p>		EXTERIOR FINISH:	
<p>DO NOT SCALE DRAWING</p>		APPLICATION	USED ON
<p>PROPRIETARY AND CONFIDENTIAL</p> <p>THE INFORMATION CONTAINED IN THIS DRAWING IS THE SOLE PROPERTY OF SPUNSTRAND INC. ANY REPRODUCTION IN PART OR AS A WHOLE WITHOUT THE WRITTEN PERMISSION OF SPUNSTRAND INC IS PROHIBITED.</p>			

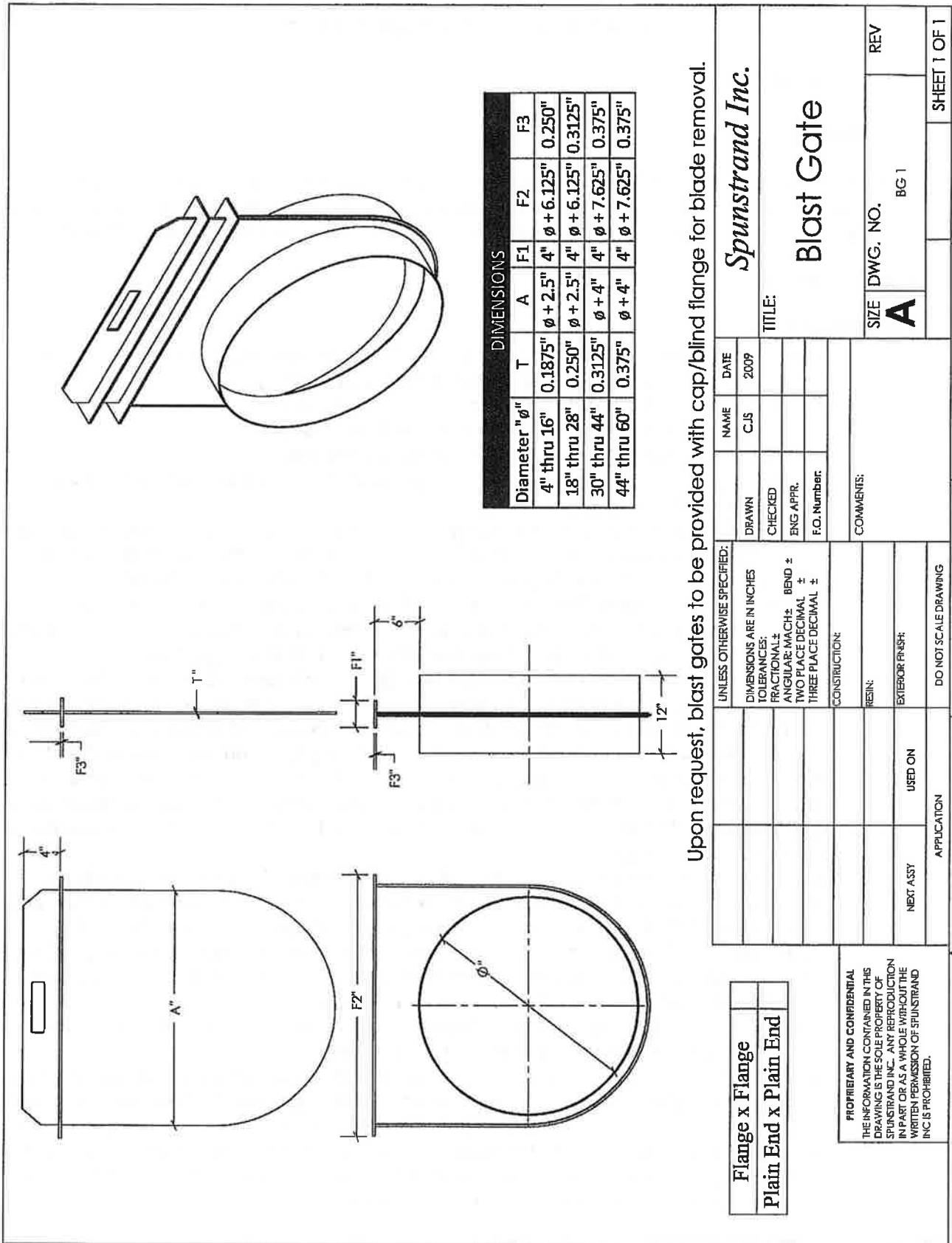

Upon request, blast gates to be provided with cap/blind flange for blade removal.

Flange x Flange
Plain End x Plain End

DRAWN		NAME	DATE
CHECKED		C.J.S	2009
ENG. APPR.			
F.O. Number:			
COMMENTS:			
RESIN:			
EXTERIOR FINISH:			
DO NOT SCALE DRAWING			
APPLICATION	USED ON		
		3	2
5	4	3	1

UNLESS OTHERWISE SPECIFIED:
DIMENSIONS ARE IN INCHES
TOLERANCES: FRACTIONAL ±
ANGULAR: MACH. BEND ±
TWO PLACE DECIMAL ±
THREE PLACE DECIMAL ±

CONSTRUCTION:
FINISH:
EXTERIOR FINISH:
DO NOT SCALE DRAWING

PROPRIETARY AND CONFIDENTIAL
THE INFORMATION CONTAINED IN THIS DRAWING IS THE SOLE PROPERTY OF SPUNSTRAND INC. ANY REPRODUCTION IN PART OR AS A WHOLE WITHOUT THE WRITTEN PERMISSION OF SPUNSTRAND INC IS PROHIBITED.

Spunstrand Inc.
Blast Gate

SIZE DWG. NO. **A** BG 1
REV

SHEET 1 OF 1

GREASE FILTER SPECIFICATION

PART 2 - Products

2.01 GENERAL

A. Fiberglass Reinforced Plastic Grease Filter (GF), as manufactured by Spunstrand® Inc. as specified and designed for continuous outdoor operation, conveying corrosive air, gasses, flammable vapors, and miscellaneous service generated by treatment of municipal wastewater.

2.02 MATERIALS

A. FRP DUCT

1. Type: Contact molded, per NBS PS 15-69, SMACNA, and rated at design pressures indicated in the drawings. Minimum wall thickness shall be:
 - .187 inches for 12" through 24" long side dimensions
 - .260 inches for 26" through 48" long side dimensions
 - .375 inches for 54" through 84" long side dimensions.
 Reinforcing ribs, or flange stiffeners as required by manufacturer, and SMACNA Thermoset Duct Construction manual.
2. All FRP GF housings shall be designed for not less than 10 inches water column pressure and 10 inches water column vacuum. The design, applicable construction, and inspections shall be in accordance with NBS PS 15-69 and SMACNA.
3. A minimum structural safety factor of 4 shall be used in the design of housing.
4. Maximum deflection of rectangular components under dead load and operating conditions shall not exceed 1 percent of the width of the longest side.
5. The resin used shall be Hetron 992SB vinylester resin selected to meet the exposures and temperatures of the air to be exhausted. Fillers other than antimony trioxide added for flame retardance when required, shall **not** be allowed, and should not exceed 5% by weight. A thixotropic agent for viscosity control may be used as recommended by the resin manufacturer. No thixotropic agent is to be used in the corrosion liner or on surfaces to be in contact with the corrosive environment. Flame spread rating shall be 25 or less per ASTM E-84. Catalyst shall be DDM9 or High Point 90 as recommended by Ashland Chemicals.
6. Corrosion liner: Inner surface shall contain two (2) plies of a 10 ml thick minimum C-glass surfacing veil saturated with polyester resin. The surface veil shall be overlapped a minimum of 1". C-veil layers to be followed with (2) layers of 1.5oz chopped strand mat, or (2) chopped spray layers, for a total minimum liner thickness of 100 mils. FRP laminate will meet NBS PS 15-69, and ASME RTP-1 Visual Level II, for visual defects. Liner shall contain 70% resin and 30% glass.
7. Structural layer shall be alternating layers of chopped strand mat and 24 ounce woven roving to meet the minimum required wall thickness.
8. Exterior of all laminates shall contain sufficient resin to ensure a surface relatively free from exposed glass fibers or sharp projections. FRP housings located outdoors shall contain an exterior colored surface coat. An ultraviolet stabilizer shall be added to the final coat of resin that also incorporates paraffinated wax curing elements. Color to be selected by owner from enclosed color chart, or will otherwise will be provided as white in color. Color should match the connecting ductwork.

2.03 EQUIPMENT FEATURES

- A. The grease filter shall consist of slide in type stainless steel removable filter pads housed inside a fiberglass reinforced plastic enclosure made of fire-retardant vinylester resin. The housing resin shall match that of the connection ductwork. The pad shall be Aircon woven 304 stainless steel pad nominal 2" thick for grease removal of 80% at 5 micron. Media shall be knitted wire mesh. Filter size is ___" by ___". Filter classification shall be minimum G2. The unit shall be sized for a facial velocity of 500 feet per minute. Pressure drop across the filter media shall not exceed 0.13 inches w.c. Transitions from round duct to the GF body, shall not exceed 30° of taper.

2.04 FIBERGLASS HOUSING

- A. The housing shall be flanged for installation in the foul air ducting. The rectangular housing flanges shall be drilled, and 1/8" butyl rubber gaskets shall be provided. 18-8 Stainless steel hardware will be provided to attach the housing inlet and outlet transitions to the main body. The round duct mating flanges will be un-drilled as provided per PS-15-69. The housing wall thickness will be built per PS-15-69 and SMACNA standards, with a minimum structural safety factor of 4 to 1. The housing shall be sized and constructed per attached shop drawing.

2.05 COMPONENTS

- A. A 1" N.P.T.schedule 80 PVC drain coupling will be provided in the bottom of the fiberglass housing. The schedule 80 PVC ball valve provided, will ship separate so as not to be damaged during shipment. If the drain ball valve is not used as a scheduled maintenance item, a p-trap should be used and connected to the drain system.

2.06 PRODUCT MAINTENANCE DATA

- A. The Aircon stainless steel Mesh filters are easily cleaned by flushing with warm tap water. (Warm water is more efficient but not necessary.) Soap or mild detergent may also be used, along with a soft bristled brush. Filters should be thoroughly dry before re-installing into the housing. Mild pressure washing can be used on Stainless type pads, with a little caution not to distort the wire mesh pads.

MIST ELIMINATOR SPECIFICATION

PART 2 - Products

2.01 GENERAL

- A. Fiberglass Reinforced Plastic Horizontal Mist Eliminator as manufactured by Spunstrand® Inc. The mist eliminator shall incorporate a wash-down spray chamber designed to provide 100 percent coverage of the pad cross section and drain system designed for 100 percent drainage of housing. The Mist Eliminator is designed to be 99% efficient on particle sizes of 10 micron or greater for continuous outdoor operation, conveying corrosive air, gasses, and miscellaneous service generated by treatment of municipal wastewater. The Mist Eliminator is designed to be 80% efficient on particle sizes of 5 micron or greater for continuous outdoor operation, conveying oils and grease generated by treatment of municipal wastewater vapors and gases. Air temperatures are expected to vary between 50 and 95°F.

2.02 MATERIALS

A. FRP DUCT

1. Type: Contact molded, or chopper gun lay-up, per NBS PS 15-69, SMACNA, and rated at design pressures indicated in the drawings. Minimum wall thickness shall be:
 - .187 inches for 12" through 24" long side dimensions
 - .260 inches for 26" through 48" long side dimensions
 - .375 inches for 54" through 72" long side dimensions
 Reinforcing ribs, or flange stiffeners as required by manufacturer, and SMACNA Thermoset manual.
2. All FRP ME housings shall be designed for not less than 10 inches water column pressure and 10 inches water column vacuum. The design, applicable construction, and inspections shall be in accordance with NBS PS 15-69 and SMACNA.
3. A minimum structural safety factor of 4 shall be used in the design of housing.
4. Maximum deflection of rectangular components under dead load and operating conditions shall not exceed 1 percent of the width of the longest side.
5. The resin used shall be Hetron 992SB vinylester resin selected to meet the exposures and temperatures of the air to be exhausted. Fillers other than antimony trioxide added for flame retardance when required, shall **not** be allowed, and should not exceed 5% by weight. A thixotropic agent for viscosity control may be used as recommended by the resin manufacturer. No thixotropic agent is to be used in the corrosion liner or on surfaces to be in contact with the corrosive environment. Flame spread rating shall be 25 or less per ASTM E-84. Catalyst shall be DDM9 or High Point 90 as recommended by Ashland Chemicals.
6. Corrosion liner: Inner surface shall contain two (2) plies of a 10 ml thick minimum C-glass surfacing veil saturated with polyester resin. The surface veil shall be overlapped a minimum of 1". C-veil layers to be followed with (2) layers of 1.5oz chopped strand mat, or (2) chopped spray layers, for a total minimum liner thickness of 100 mils. FRP laminate will meet NBS PS 15-69, and ASME RTP-1 Visual Level II, for visual defects. Liner shall contain 70% resin and 30% glass.
7. Structural layer shall be alternating layers of chopped strand mat and 24 ounce woven roving to meet the minimum required wall thickness.

8. Exterior of all laminates shall contain sufficient resin to insure a surface relatively free from exposed glass fibers or sharp projections. FRP housings located outdoors shall contain an exterior colored surface coat. An ultraviolet stabilizer shall be added to the final coat of resin that also incorporates paraffinated wax curing elements. Color to be selected by owner from enclosed color chart, or will otherwise will be provided as a gray or off-white color. Color should match the connecting ductwork.

2.03 EQUIPMENT FEATURES

- A. The Mist eliminator shall consist of a slide in type polypropylene removable mesh pad housed inside the fiberglass housing. The mesh pad shall be Kimre woven polypropylene nominal 4" thick.
- B. The optional grease filter pad shall be Aircon woven 304 stainless steel pad nominal 2" thick for grease removal of 80% at 5 micron.
- C. An internal wash nozzle shall be provided to enable wash-down spraying of 100 percent of the mesh pad. Nozzles shall be polypropylene and the piping shall be PVC with a 3/4" half coupling connection on the side of the mist eliminator.
- D. A Dwyer 2003 magnehelic gauge will be mounted on the outside of the housing with polyethylene tubing attached to 1/8" FPT coupling on the inlet and outlet transitions. The range of the magnehelic is 0-3" W.C. The overall static pressure drop of the mist eliminator system is 1.5" W.C.

2.04 FIBERGLASS HOUSING

- A. The housing shall be flanged for installation in the foul air ducting. The rectangular housing flanges shall be drilled, and 1/8" butyl rubber gaskets shall be provided. 18-8 Stainless steel hardware will be provided to attach the housing inlet and outlet transitions to the main body. The round duct mating flanges will be un-drilled as provided per PS-15-69. The housing wall thickness will be built per PS-15-69 and SMACNA standards, with a minimum structural safety factor of 4 to 1. The housing shall be sized and constructed per attached shop drawing.

2.05 COMPONENTS

- A. A 1" N.P.T. schedule 80 PVC drain coupling will be provided in the bottom of the fiberglass housing. The schedule 80 PVC ball valve provided, will ship separate so as not to be damaged during shipment. If the drain ball valve is not used as a scheduled maintenance item, a p-trap should be used and connected to the drain system.

2.06 PRODUCT MAINTENANCE DATA

- A. The optional Aircon stainless steel Mesh filters are easily cleaned by flushing with warm tap water. (Warm water is more efficient but not necessary.) Soap or mild detergent may also be used, along with a soft bristled brush. Filters should be thoroughly dry before re-installing into the housing. Mild pressure washing can be used on Stainless type pads, with a little caution not to distort the wire mesh pads.

FIBERSONIC SILENCER™ CONSTRUCTION SPECIFICATION

10/1/09

1.01 GENERAL

Fiberglass Reinforced Plastic Silencers shall be **manufactured by Spunstrand® Inc. and David P. Wilson FiberSonic Model FS-00-00-00**, or pre-approved equal. Silencer shall be tested for insertion loss, self noise and pressure drop in an independent NVLAP accredited laboratory in full accordance with ASTM E477. Testing shall be completed and data available for review, 72 hours prior to bid date.

1.02 MATERIALS

A. Shell

1. FRP Shell shall be filament wound rated at design pressures as indicated on the drawings, Shell shall be type 1, grade 2 RTRP Polyester, or Vinylester Class E per ASTM D-2310. All shells shall be designed for not less than +20" SPWG pressure and -12" SPWG vacuum.
2. Resin shall be Hetron 99P or Hetron 992SB, selected to meet the exposures and temperatures of the air to be exhausted. Fillers, other than those added for flame retardance when required, shall not be allowed. Flame spread rating shall be 25 or less per ASTM-E84.
3. The corrosion liner shall contain a 20 mil thick minimum surface veil saturated with resin consisting of approximately 90% resin and 10% glass by weight. The surface veil shall be overlapped a minimum of 1".
4. The structural layer shall be filament wound of type A premium grade polyester resin and glass as required for the specific working conditions.
5. The exterior of the shell shall contain sufficient resin to ensure a relatively smooth surface, free from exposed glass fibers or sharp projections, and shall contain an ultraviolet light inhibiting agent.
6. The shell shall have sufficient strength to exhibit, without structural damage, a minimum rated stiffness in accordance with ASTM D-2412.
7. Shell manufactured with a composite structural wall containing sand, alumina or other granular fillers are not acceptable.

B. Liner(s)

1. The airstream liner shall be 1/8" thick perforated polypropylene.
2. Liner shall be suitably sealed to contain acoustic insulation.
3. Liner shall be braced with FRP reinforcement rings to prevent unreasonable deflection.
4. Insulation shall be contained by .065" thick fiberglass fabric sheeting.

C. Acoustic Insulation

1. Insulation shall be 4 lb / ft³ density basalt mineral wool.

D. Center-body

1. If required for additional noise reduction, a cylinder shaped center-body shall be located within the silencer. Center-body shall have the same acoustic insulation, and liners as listed above.
2. Center-body shall be adequately supported by FRP braces.

FIBERSONIC SILENCERS™

FRP SOUND CONTROL SILENCERS FOR POLLUTION CONTROL SYSTEMS

Description:

Spunstrand® Inc. Fibersonic Silencers™ are made of Fiberglass Reinforced Polyester and can be used where corrosive air streams prevent the use of standard metal silencers. Designed for use in waste water treatment plant exhaust systems where sound control is as essential to the environment as pollution control. Available in sizes up to 72" ID and 144" length. *Pictured at the right, is the Model FS-48-120.*

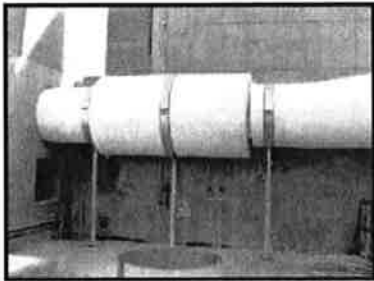

Construction Features:

- FRP Outer Body Casing
- FRP Center Body Supports
- 1/8" Perforated Polypropylene Liner
- Perforated Polypropylene Center Body Shell
- Mineral Wool Acoustic Insulation
- Available With & Without Center Body

ACCOUSTICAL DATA with CENTER BODY								
OCTAVE BAND CENTER FREQUENCY								
Insertion Loss (dB) 0 FPM Velocity	63	125	250	500	1000	2000	4000	8000
		2	13	24	29	34	24	18
Above data based on Fibersonic Model #FS24-48CB. Silencer has been tested for insertion loss, self-noise and pressure drop in a NVLAP accredited acoustical laboratory in full accordance with ASTM E477.								

ACCOUSTICAL DATA without CENTER BODY								
OCTAVE BAND CENTER FREQUENCY								
Insertion Loss (dB) 0 FPM Velocity	63	125	250	500	1000	2000	4000	8000
		1	13	21	15	14	10	9
Above data based on Fibersonic Model #FS24-48. Silencer has been tested for insertion loss, self-noise and pressure drop in a NVLAP accredited acoustical laboratory in full accordance with ASTM E477.								

PRODUCT INFORMATION CONCERNING SHIPPING, HANDLING and STORAGE

RECEIVING:

Regardless the mode of transportation, upon receiving, each piece should be inspected and checked against the Packing Slip / Bill of Lading.

INSPECTION:

Note damaged or missing items on the Bill of Lading and notify the carrier's agent (*truck driver*). Obtain a signed acknowledgement of the damage or shortage at the time of unloading. **DO NOT** dispose of or return damaged items. Replacement materials must be re-ordered on a separate Purchase Order. Shipments are FOB factory – *Wallace, Idaho*. Once materials are loaded and leave the Spunstrand® Inc. factory, title of materials pass to the consignee – *customer*. If you do not note the damage and assist in filing a freight claim, any warranty work or replacement parts will be charged to the customer.

UNLOADING:

Small parts may be unloaded by hand but not thrown off the truck. Handle parts carefully, being sure not to scratch the interior surface or damage the ends.

- **DO NOT** push or roll duct off the truck with a fork lift.
- **DO NOT** use hooks to lift duct.
- **DO NOT** use wire rope or chains as a sling to lift large duct.

If slings are to be used, they must be a minimum of 4" wide webbed nylon or canvas. On 20 foot lengths of large duct, two slings should be placed approximately 7 feet in from each end, and the load lifted evenly. On 40 foot lengths, three slings placed at 10 foot intervals should be used.

STORAGE:

It is important that the resin and glass materials be stored out of the weather in a clean, dry location within a maximum temperature of 77°F. Cover all product (glass, duct) with a protective tarp. The glass materials and product should be covered to protect them from rain and snow. Keep resin out of the sun and store in an area where the temperature will not fall below 60°F. Read the labels on all containers, the labels contain information about health and safety considerations as well as storage. Store and handle the duct and fittings so as to prevent damage. Note that most coated industrial duct arrives on-site wrapped in protective wrapping that is applied as an additional service by Spunstrand® Inc. to protect the product during transit. It is Spunstrand's recommendation that all gel coated ductwork be unwrapped immediately upon arrival to avoid any variations in coating consistency. All though very rare, any detrimental effects of leaving gel coated ductwork wrapped is not the responsibility of Spunstrand® Inc. Ductwork that is coated in intumescent paint can be stored in the protective wrap and should be stored out of the weather and away from moisture as both will affect the coating. For any questions regarding storage of our ductwork, please contact your local Spunstrand® Inc. Representative.